

(BI-SJIEHS-396010-B07)

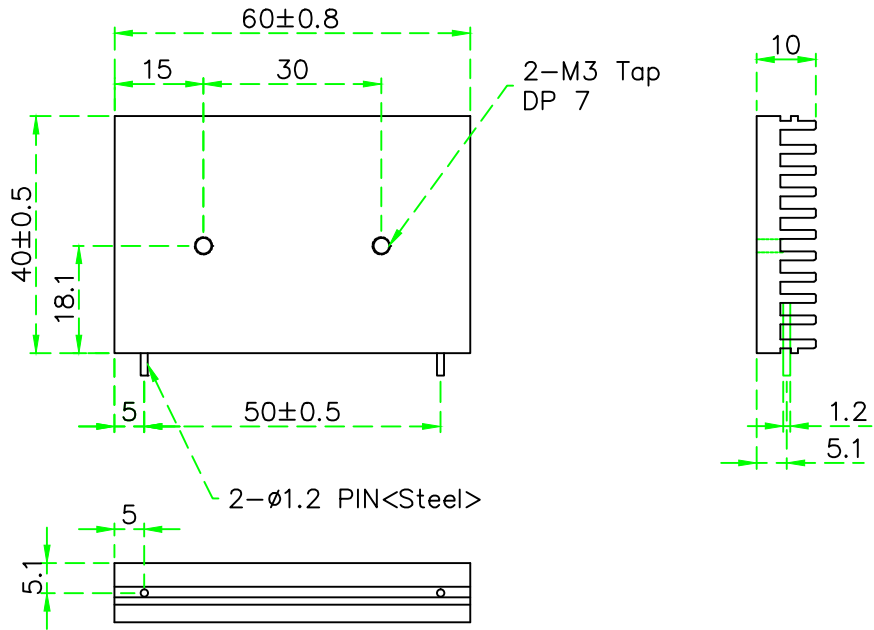

(BI-SJIEHS-396010-B08)

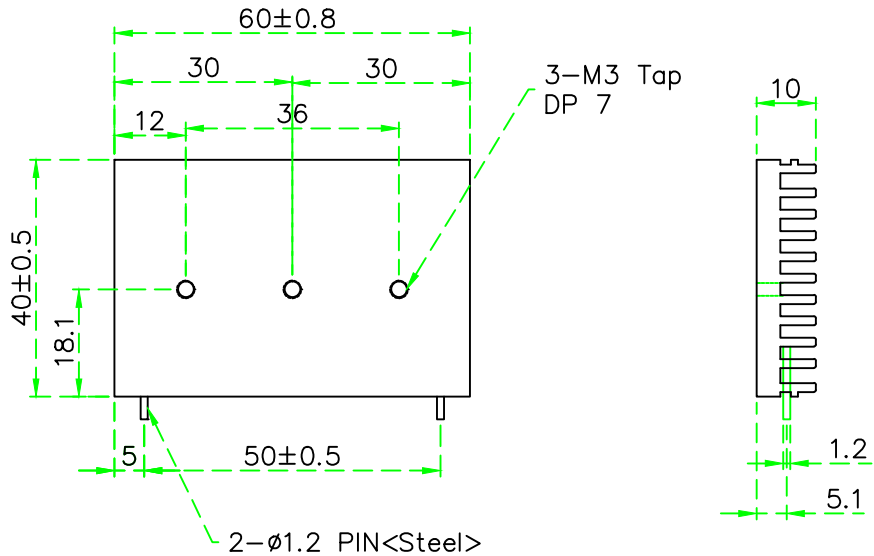

NOTE

1. 지시하지 않은 공차 : GENERAL TOLERANCES

GENERAL TOLERANCES			Part Name.		Dwg No.		
0 ~ 10	±0.3	±1.5°	HEAT SINK				
10 ~ 20	±0.5						
20 ~ 50	±0.8		Drawing BY.	Checkd BY.	Approval BY.	Sheet No.	of
50 ~ 100	±1.0						
Scale	/		(주)부일일렉트로닉스 BUIL ELECTRONICS CO., LTD.				
Materral	AL6063						
Finish	Black anodizing						