

4					Current rating	AC250V 10Amp
3	Screw	Steel	Ni	M3.5	Insulation resistance	1000M Ohms of More at DC500V
2	Terminal	Brass	TIN	1/2H	Withstand voltage	AC2000V/Minute
1	Base	PBT		UL94 V-0	Wire range	AWG #14~#22
A	Part Name	Material	Plating	Remark	Torque	6.9 lb-in

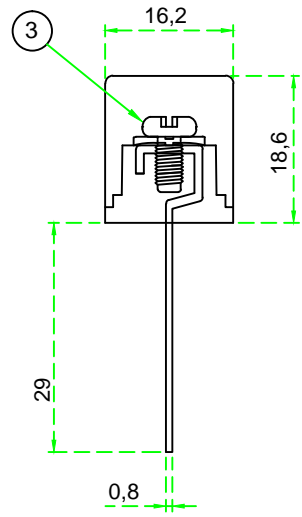
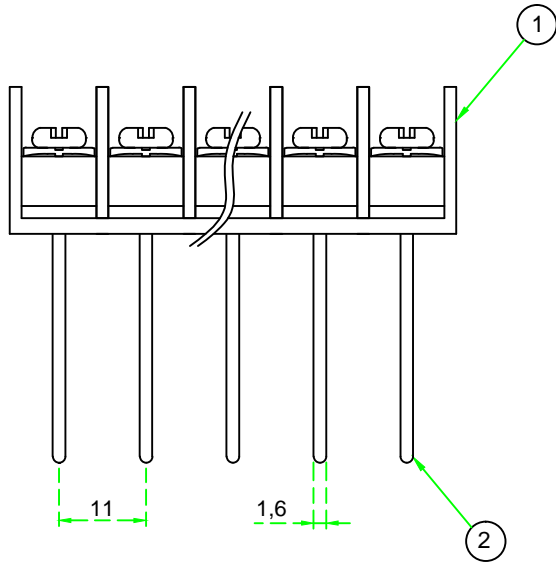
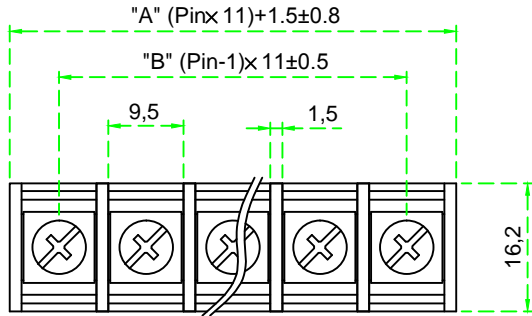

PCB hole Dia:  $\phi 2.0$

(Option)

1. Cover 사용시 No: BI-11A-2SC- \*P

(Note)

2. 지시하지 않은 공차: **GENERAL TOLERANCES**

GENERAL TOLERANCES		Part Name.	Dwg No.	
0 ~ 50	$\pm 0.5$	Terminal block	BI-11A-2S- * P	
50 ~ 100	$\pm 0.8$			
100 ~ 150	$\pm 1.0$	Drawing BY.	Checkd BY.	Approval BY.
150 ~ 200	$\pm 1.2$			
Scale	/	Sheet No.		of
Material		(주)부일일렉트로닉스 BUIL ELECTRONICS CO., LTD. www.ebuil.com		
Finish				